

INSTALLATION AND MAINTENANCE MANUAL

Motorized Projector Lift

mod. **SI-H XL 300**

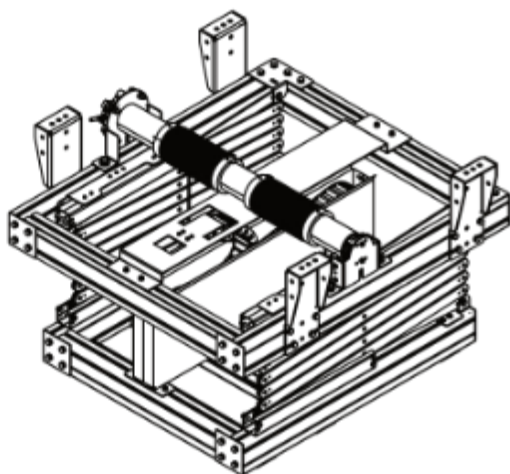

mod. **SI-H XL 500**

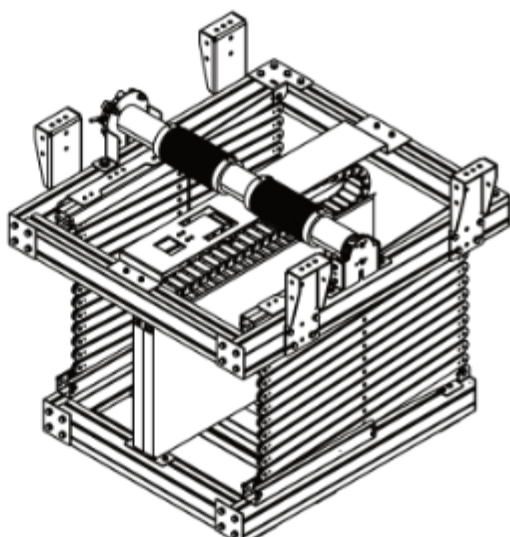

ORIGINAL INSTRUCTIONS IN ITALIAN LANGUAGE
Translation into English language

1.0 - WARNINGS

Thank you for purchasing this motorized Projector Lift.

This is supplied with a set of components and accessories that make it suitable for installation for the majority of standard AV applications, but note must be made of the restrictions that apply to the weight capability of this unit and not exceeded.

PLEASE READ THE FOLLOWING INSTRUCTIONS CAREFULLY IN ORDER TO BE SURE TO MAKE A CORRECT INSTALLATION WHICH WILL ASSURE SAFETY AND A LONG TERM USABILITY.

Please, always keep these instructions ready so that anyone can read them when needed.

THE MANUFACTURER DOES NOT TAKE RESPONSIBILITY FOR ANY DAMAGE TO PROPERTY OR PERSONAL INJURY IF THE PROJECTOR LIFT IS USED OUTSIDE OF RECOMMENDED SPECIFICATIONS OR IN CASE OF INCORRECT INSTALLATION.

BEFORE INSTALLING THE PROJECTOR LIFT, PLEASE READ THE FOLLOWING INSTRUCTIONS CAREFULLY:

- The projector lift must be used **INDOORS ONLY**.
- **INSTALLATION OF SI-H XL 300 OR SI-H XL 500 PROJECTOR LIFT HAS TO BE CARRIED OUT FROM QUALIFIED PERSONNEL ONLY.**
- **IT IS FORBIDDEN TO STAY UNDER THE LIFT AND WITHIN A RANGE OF 3 MT. FROM THE LIFT.**

- **NEVER connect more than one motor to the same switcher. USE THE SUPPLIED REMOTE CONTROL ONLY.**

- **IN CASE OF MAINTENANCE, UNPLUG THE POWER SUPPLY FROM THE LIFT.**

- Please take care that your projected image width will fit your screen from the lift's mounting location prior to install the product.

- During operations of rolling down and rolling up the motor will warm up, this is normal.

- Incorrect use of the lift, including exceeding the maximum lifting weight, will be dangerous. The manufacturer does not take responsibility for any damage o property or personal injury if the lift is used outside of recommended specifications.



- Incorrect use of the projector lift, including exceeding the maximum lifting weight of 95 kg., would be dangerous and invalidates the warranty.

- This product is equipped with a 230V AC Motor. **DO NOT attempt to service the motor.**

- For any repairing, please contact directly the dealer you purchased the unit from.

- **DO NOT** try to disassemble the lift or to paint the structure, as these operations will invalidate the warranty.
- It is compulsory the half-yearly and yearly check. Please fill in the requested fields on the check register at page 22 of this document. If the check register is not filled in, warranty will be voided.
- In addition to manufacturer inspection guidelines, we recommend you check your countries own legal obligations for checking and testing of lifting equipment.

THE MANUFACTURER AND ITS DISTRIBUTORS AND DEALERS DO NOT TAKE RESPONSIBILITY FOR ANY DAMAGE TO PROPERTY OR PERSONAL INJURY IF THE WINCH IS INSTALLED/USED OUTSIDE OF RECOMMENDED SPECIFICATIONS.

**THE MOTORIZED LIFTS
MOD. SI-H XL 300 AND MOD. SI-H XL 500
ARE   CERTIFIED**

2.0 - WARRANTY CONDITIONS

This projector lift is guaranteed 2 years from the purchase date for manufacturing defects and 5 years on motor defects.

Responsibility is limited to repairing or substitution of the defected components and without any other charge at our expense.

Warranty is officially voided if (all the following cases are including but not limited):

- 1) defects not due to deficiencies in the material or workmanship;
- 2) amendments, alterations, repairs or disassembling of the Product not previously authorized in writing by Screenint;
- 3) installation, use or maintenance of the Product not in compliance with Screenint's instructions as set forth in this Installation Manual and/or in any other technical documentation supplied together with the Product;
- 4) bad and/or improper and/or not in compliance installation, maintenance, negligence, improper use;
- 5) use of non-original spare parts or not authorized in writing by Screenint;
- 6) normal wear and tear;
- 7) the motor is removed / dismantled;
- 8) the projector lift has been damaged in transit;
- 9) the instructions regarding the electrical connections have not been followed;
- 10) the products have to be installed following the electric regulations (CEI) and the other local specific laws;
- 11) in the installation are used electric interfaces that does not allow the correct time lapse between up and down operation (complete cut down of electric power on both phases for one second);
- 12) electrical accessories have been used that are incompatible with the lift motor causing damage to its internal components;
- 13) the sticker regarding the serial number of the product has been altered, deleted, removed or tampered.

3.0 - PACKAGING AND SUPPLIED EQUIPMENT LIST

When you open the packaging, please CHECK that it contains ALL the components below listed. In case one or more components are missed, please refer to the dealer you purchased the product from.

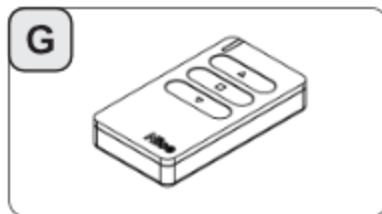
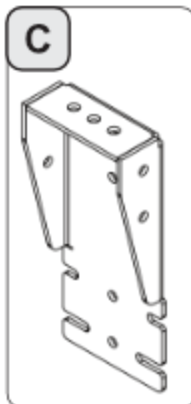
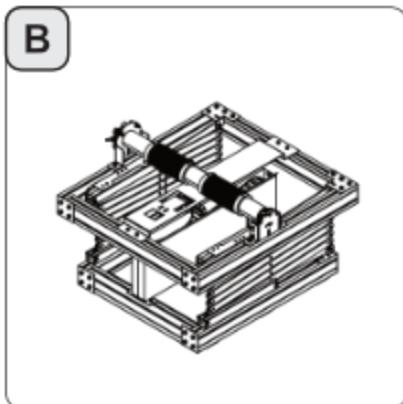
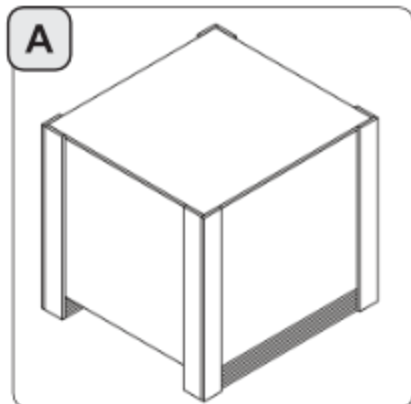

Pos.	Q.ty	Description
A	x 1	Wooden crate
B	x 1	Motorized Projector Lift SI-H XL 300/500
C	x 4	Metal brackets for ceiling mounting
D	x 16	Socket head screws M8x20
E	x 16	Washers 16x8,5x1,5
F	x 16	Crowned nuts 13x13x6 M8
G	x 1	RF remote control
H	x 1	Remote control support
I	x 1	Installation manual

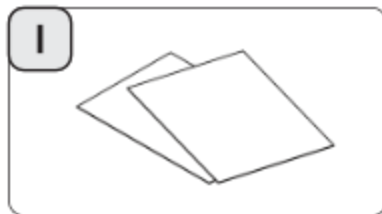
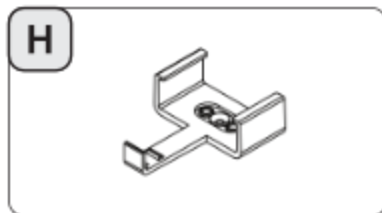

4.0 - MOTORIZED PROJECTOR LIFTS' DIMENSIONS

4.1 - PROJECTOR LIFT SI-H XL 300

Side View

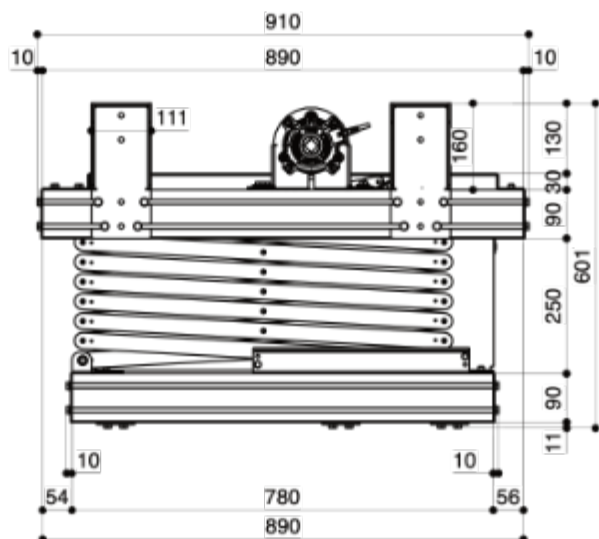

Frontal View

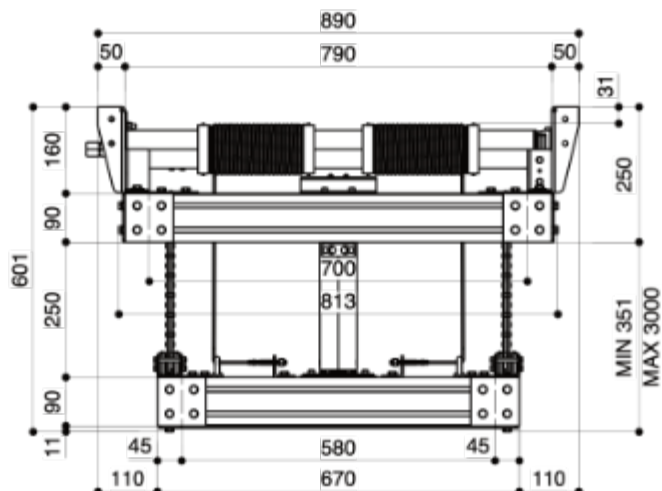

Upper view of the top structure

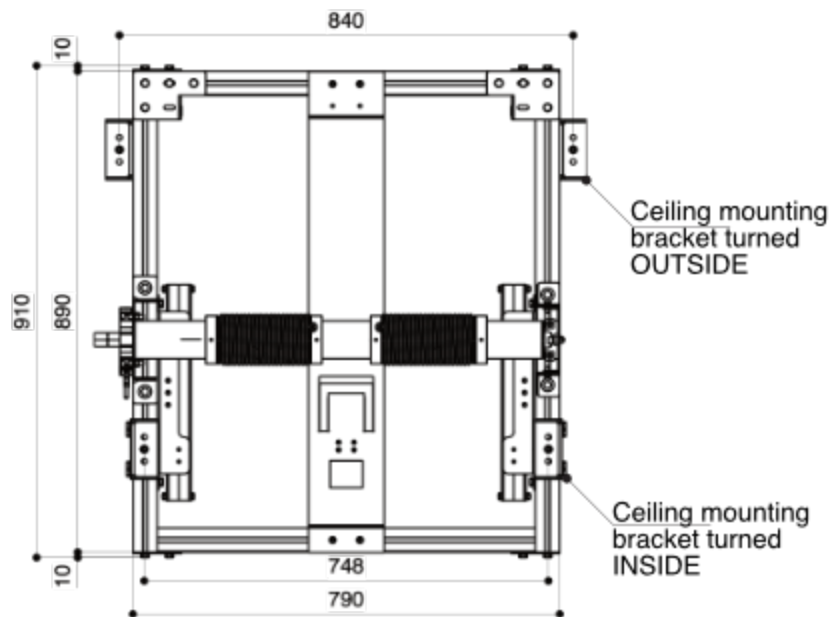

Upper view of the bottom structure

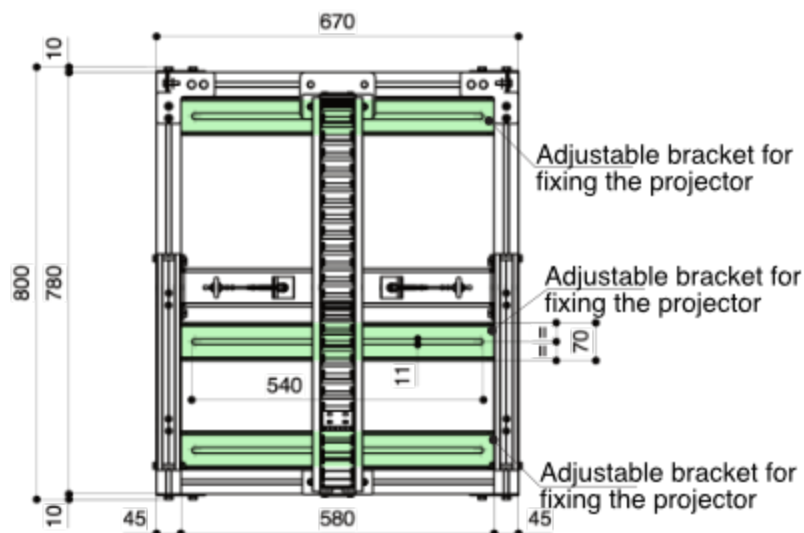

4.2 - PROJECTOR LIFT SI-H XL 500

Side View

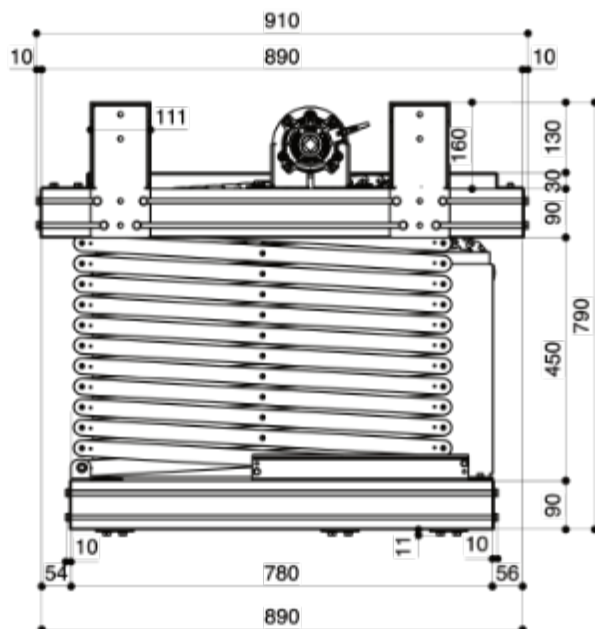

Frontal View

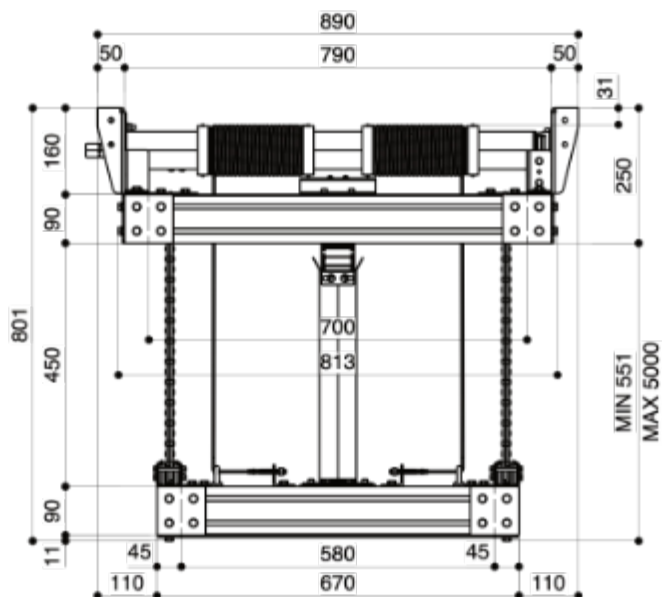

Upper view of the top structure

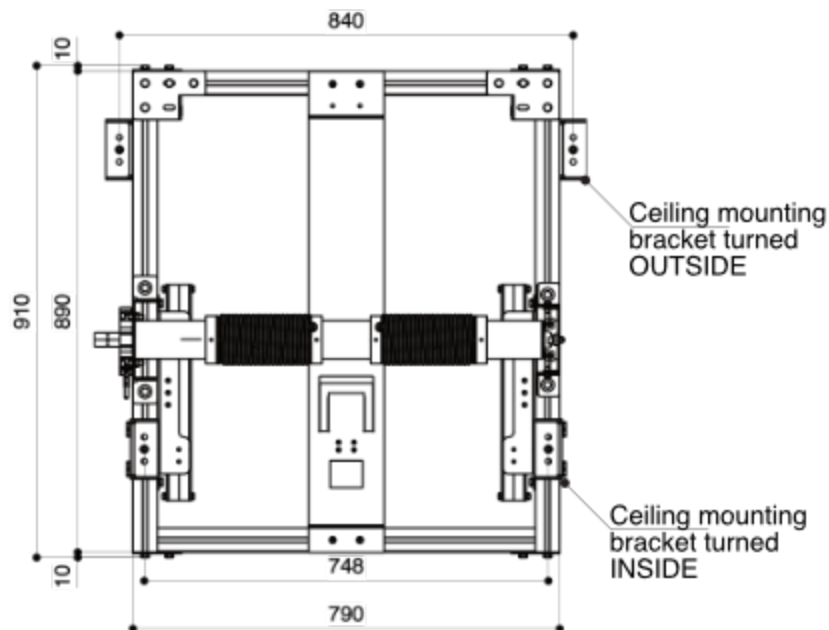

Upper view of the bottom structure

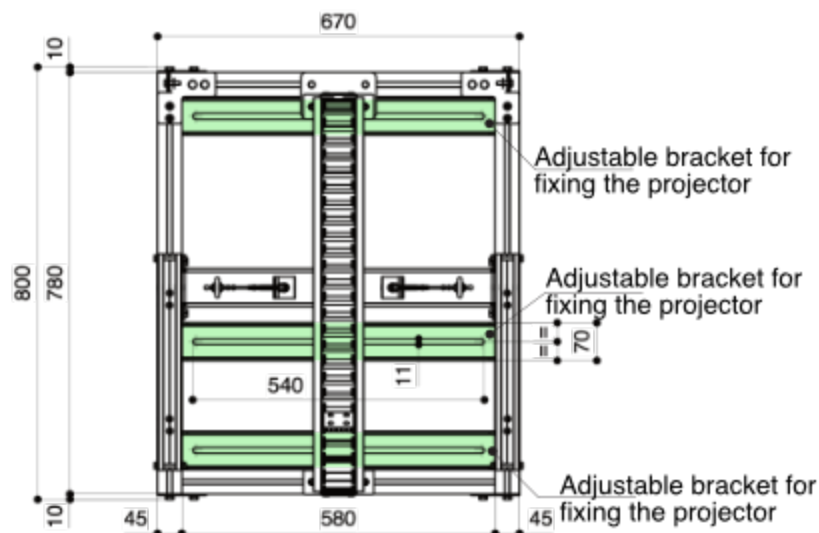

5.0 - INSTALLATION

Mount the four metal brackets (C) on the upper aluminum frame of the lift, using the splines of the upper frame both on the right and on the left hand side, as per drawing below.

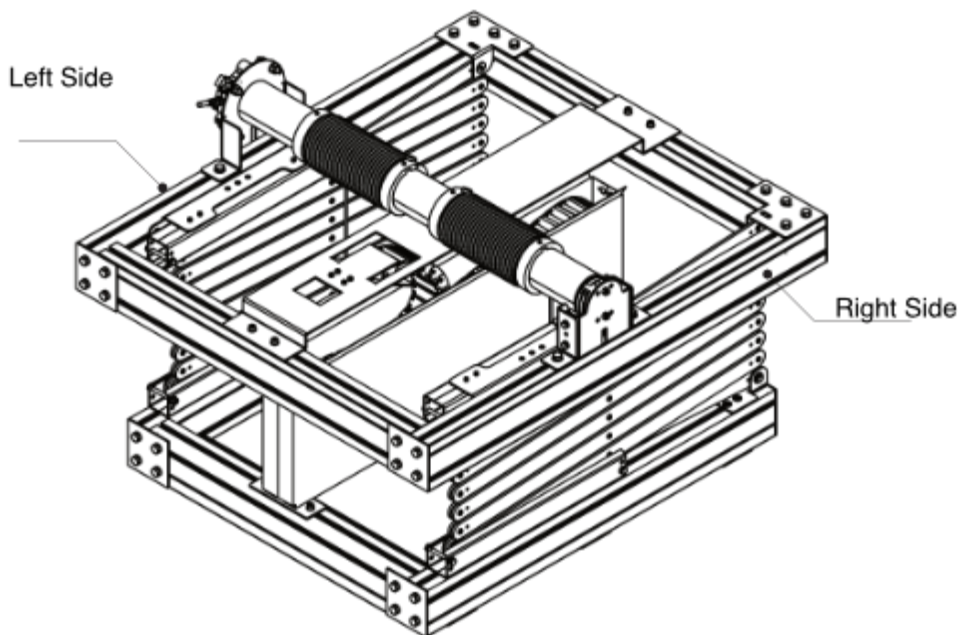

Put inside the spline of the aluminium frame the crowned nut (F) as shown below. For each metal bracket insert nr. 2 socket head screws, washers and crowned nuts on the upper spline and nr. 2 socket head screws, washers and crowned nuts on the bottom spline and screw them partially.

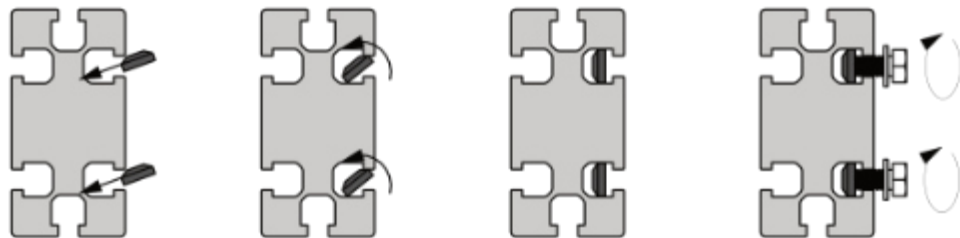

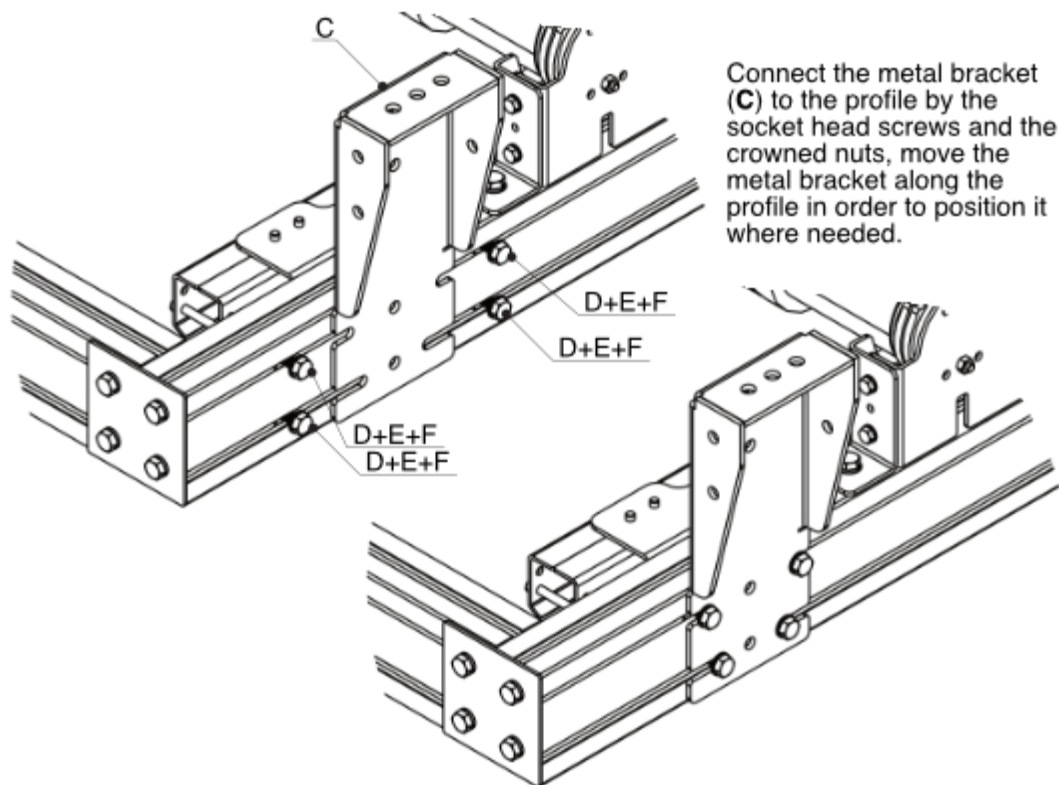

the four metal brackets can be mounted in two different ways on the upper frame of the lift:

Bracket turned
OUTSIDE

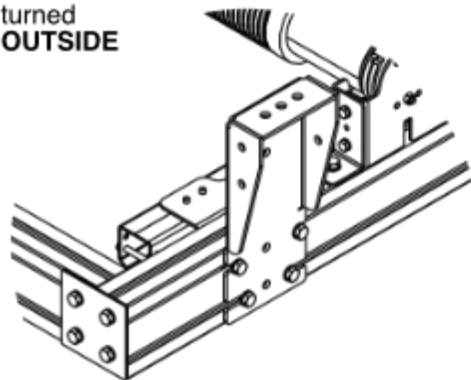

Bracket turned
INSIDE

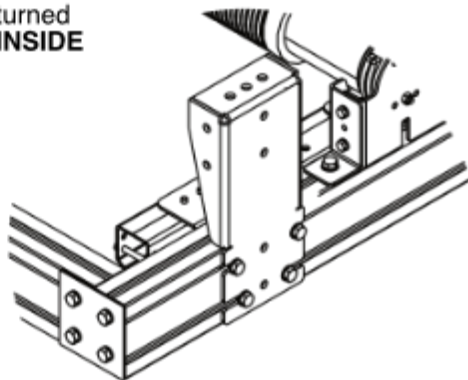

Position the metal brackets as indicated in the drawing below, tighten firmly the socket head screws.

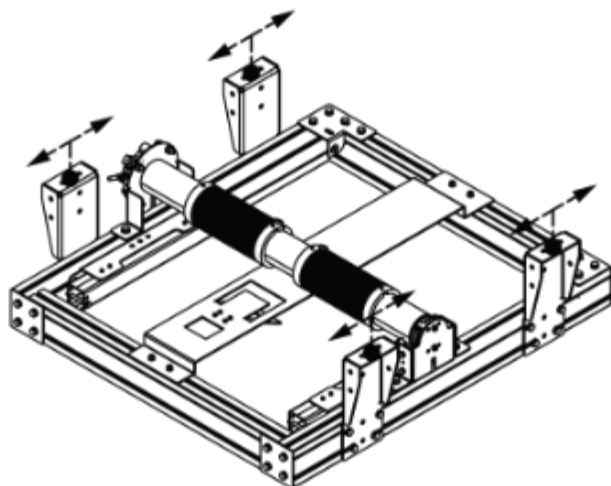

Mount the lift onto the ceiling (screws and plugs NOT supplied), taking care that the upper profile is perfectly levelled, both in depth and in width.

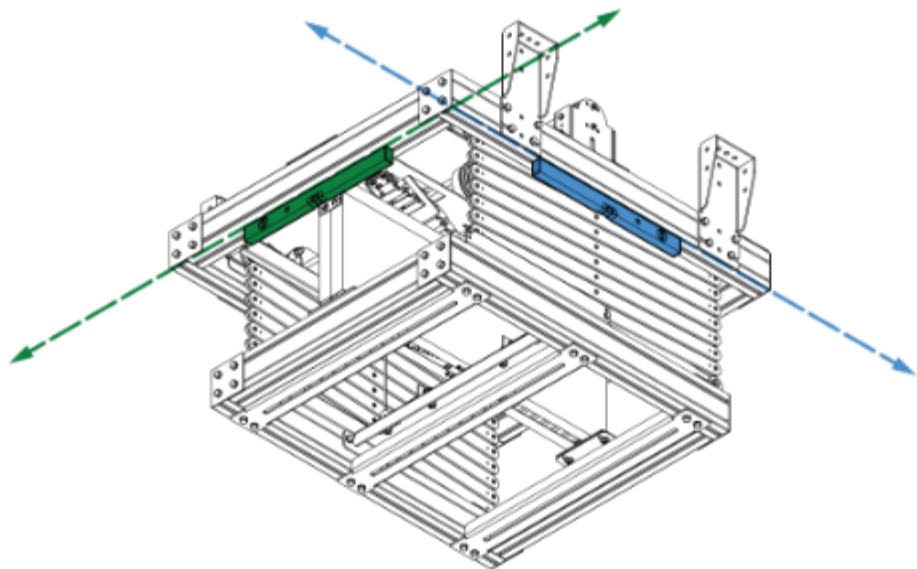

6.0 - ELECTRICAL CONNECTION

The motor has the possibility to be controlled via the supplied handheld RF remote control or via wired low voltage contact closures.

CONNECT THE DEVICE TO THE MAINS BY USING A THERMAL OR MAGNETOTHERMIC SWITCH OF 2 AMPERE.

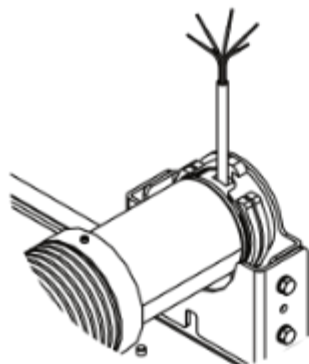
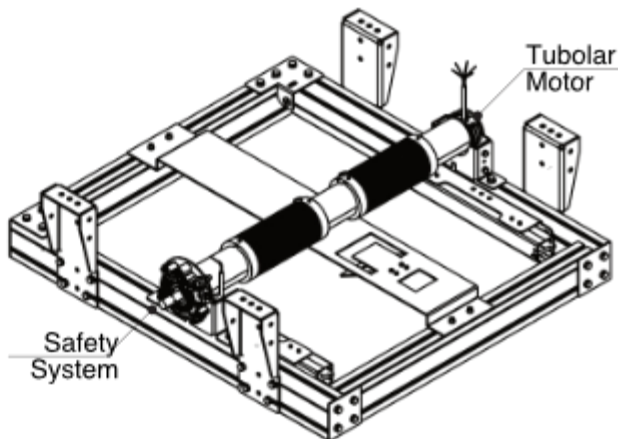

TUBULAR MOTOR

The motor has a six-core power cable:

- BLUE (Neutral)
- BROWN (Phase)
- GREEN/YELLOW (Earth)
- **WHITE**
- **WHITE-BLACK**
- **WHITE-ORANGE**

DO NOT CONNECT TO THE MAINS

SAFETY SYSTEM

The safety system assures a double type of safety:

- 1- **Mechanical** which locks the unrolling of the steel cables in case of exceeding speed of 50 rpm.
- 2- **Electrical** which disconnect the mains from the motor in case the force exerted on the steel cable, due to the fall, is more than 503 Nm.

The safety system is equipped with a two-core cable:

- BLUE
- BROWN

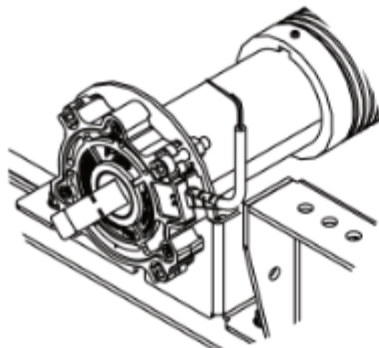

This is the electrical connection scheme:

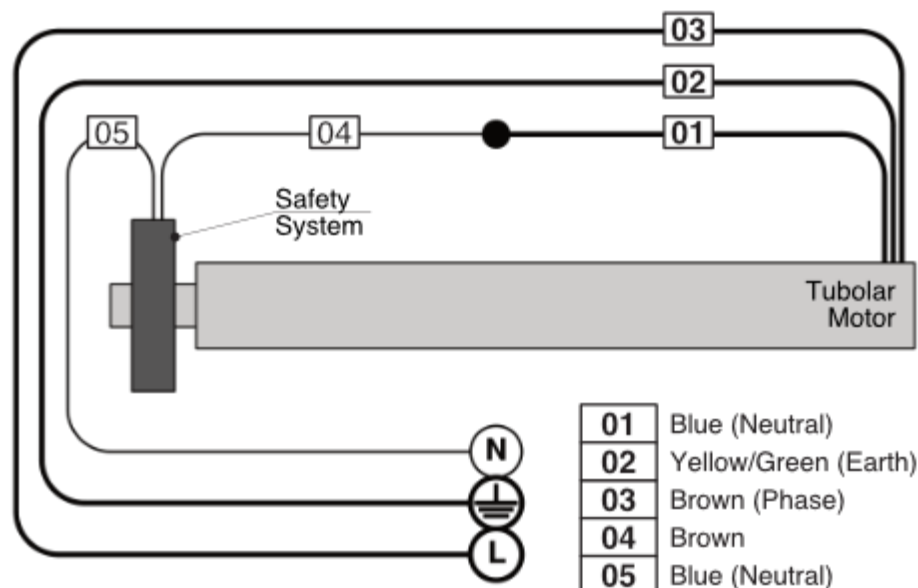

The projector lift includes a CABLE MANAGEMENT SYSTEM.

In order to fit in the power and signal cables of the projector move the lift in the lower end stop position (SERVICE MODE) and open the small doors, as shown in the drawing below.

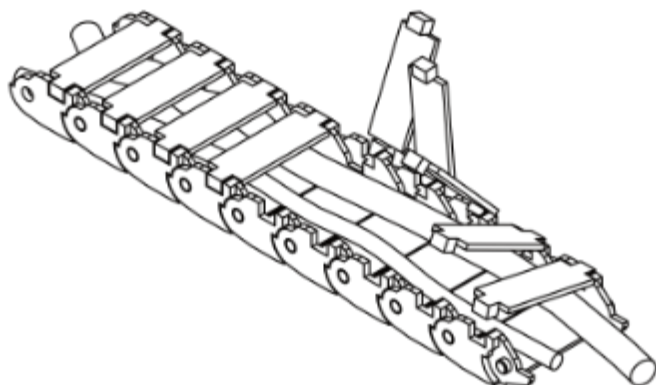

7.0 - TECHNICAL DATA

7.1 - PROJECTOR LIFT SI-H XL 300

Power supply	230 VAC / 50 Hz
Max Consumption	360 W
Motor Speed	12 rpm
Roll Up / Down Speed	17 sec./metre
Thermal protection	after 4 min of operation
Net weight SI-H XL 300 lift	71 Kg
Maximum load of the projector	95 Kg
Dimensions SI-H XL 300 Closed	790x895x601 mm. (WxDxH)
Dimensions SI-H XL 300 Opened	790x895x3351 mm. (WxDxH)

7.2 - PROJECTOR LIFT SI-H XL 500

Power supply	230 VAC / 50 Hz
Max Consumption	360 W
Motor Speed	12 rpm
Roll Up / Down Speed	17 sec./metre
Thermal protection	after 4 min of operation
Net weight SI-H XL 500 lift	81 Kg
Maximum load of the projector	95 Kg
Dimensions SI-H XL 500 Closed	790x895x790 mm. (WxDxH)
Dimensions SI-H XL 500 Opened	790x895x5551 mm. (WxDxH)

8.0 - FIXING OF THE VIDEOPROJECTOR

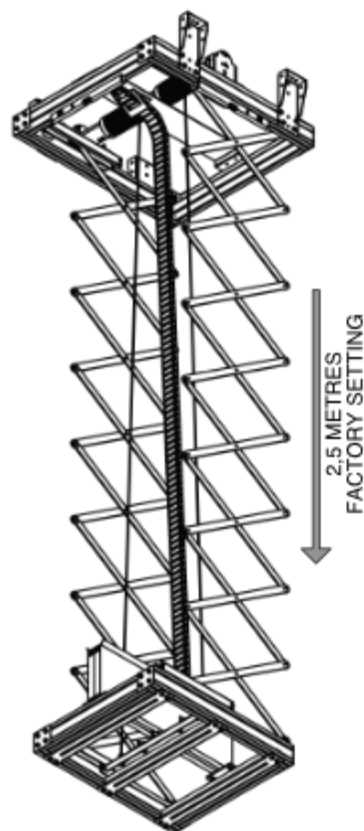

Roll down the lift by pushing ▼ button on the remote control, in order to lower the lift till the lower end-stop (SERVICE mode), preset in the factory at approx. 2,5 mt.

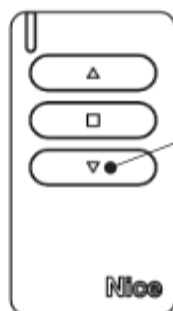

Push for at least
1 sec.

In case you wish to modify the lower end-stop (SERVICE mode), please refer to instructions at page 20.

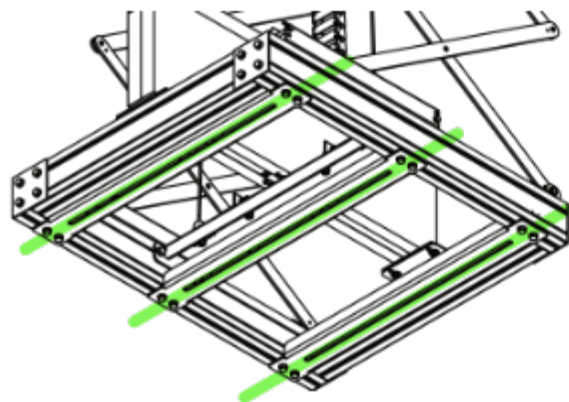

In order to fix the projector under the lift, position the splines of the three profiles of the lower lift frame, to match the anchoring points on the projector.

Unloose the four screws as shown on the drawing below and position the three profiles where needed.

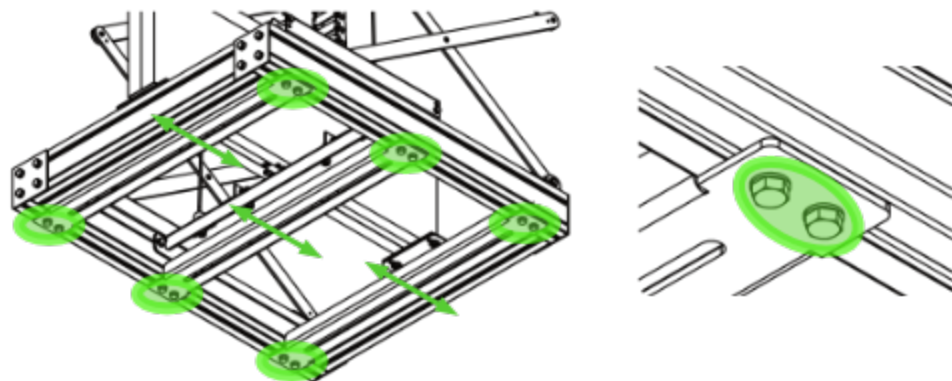

Once you have aligned the splines of the profiles with the anchoring points on the projector, tighten the screws and the bolts of the profiles following a cross scheme.

9.0 - ADJUSTMENT OF PITCHING AND ROLLING OF THE PROJECTOR

Projectors have not a regular distribution of the weight on their surface but tend to have unbalancing caused by the lamp, by the optical system and so on. Unbalancing could lead to either a right and left rolling or a pitching of the lower lift frame . projector.

The lift has been developed to solve these problems and allow to adjust the lift in order to get a perfect balance of the entire lifting system.

In order to adjust **PITCHING**, please move the motor hoist and the projector+bottom frame along the profile where the motor itself is fixed, by loosening the screws as shown on the drawings below and move the motor left or right until the lower frame will be perfectly balanced.

IN ORDER TO PROCEED WITH THIS ADJUSTMENT IT IS IMPORTANT TO REDUCE THE WEIGHT OF THE MOTOR HOIST AND PROJECTOR+BOTTOM FRAME LAYING IT ONTO A SUPPORT.

Now loose the screws as shown on the drawings below and using a rubber hammer, move the profile, left or right in order that the steel cables are perpendicular both to the upper part and to the lower part of the lift as shown in the left drawing.

At the end of the adjustment, tighten the screws firmly.

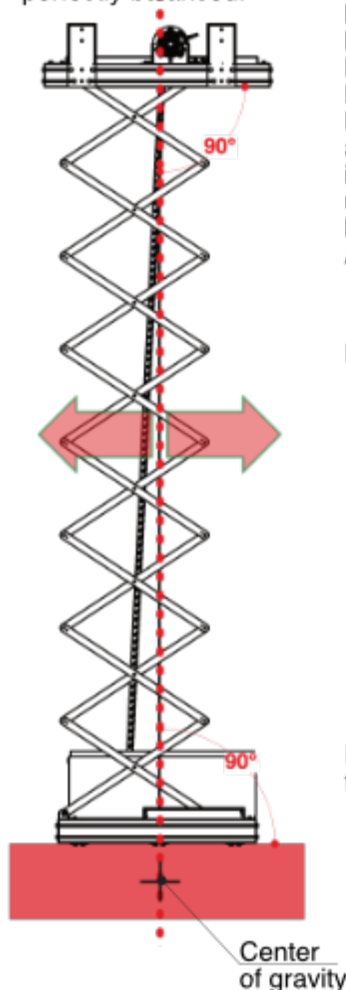

Motor Hoist

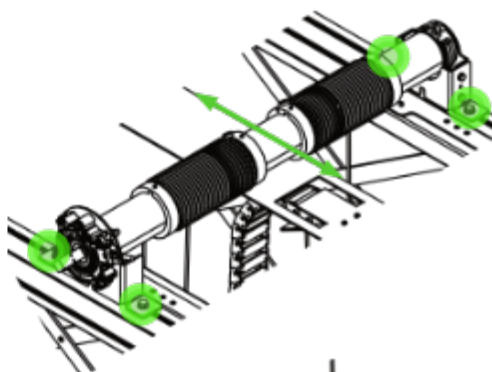

Projector+bottom frame

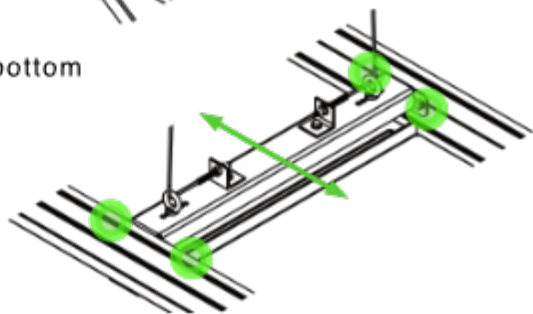

In order to adjust **ROLLING**, please tighten or unloose the nuts that act on the tension of the steel cables.

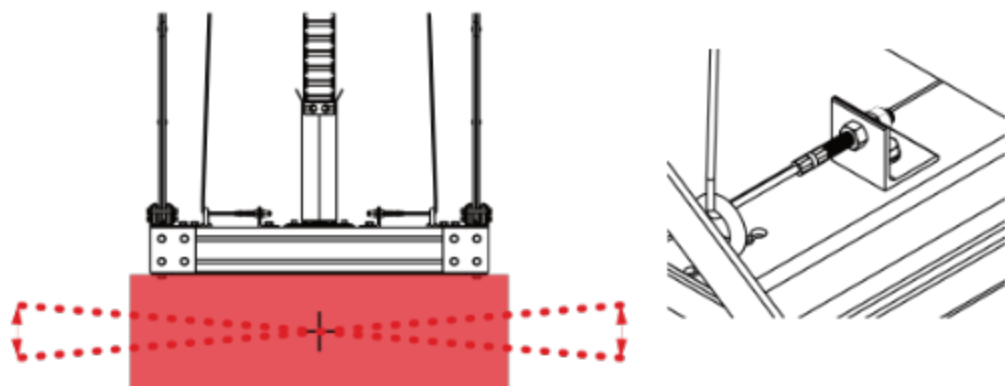

10.0 - ADJUSTMENT OF THE END STOPS

The SI-H XL 300 and the SI-H XL 500 motorized lifts are supplied with a remote control that allows to set three stop positions:

1- **CLOSED LIFT**: preset by the factory, in closed upper position.

WARNING: in case the installer needs to modify this end-stop, it is **ONLY** allowed to lower the upper end-stop position. **Do not try to raise the upper end-stop because this will cause severe damages to the product and this operation will invalidate the warranty.**

2- **PROJECTION MODE**: intermediate stop position, NOT preset by the factory.

3- **SERVICE MODE**: lower end-stop position, preset by the factory at 2,5 mt. circa.

WARNING: Before setting the end stops, the low voltage contact wires have to be isolated from each other.

A - SETTING THE LOWER END STOP (SERVICE MODE position)

- Lower down the lift till half stroke, pressing the remote control button ▼ and stop it with button ■.

- Press the button ■ (for 5 secs) till the motor swivels 2 times.

- Press again the button ■ (for 5 sec) till the motor swivels 4 times.

- Press the button ▼ (for 5 sec) till the motor swivels 2 times.

- Press and hold the buttons ▼ or ▲ in order to reach the desired position of the lift.

WARNING: during this programming operation you have to keep the buttons ▼ or ▲ pressed in order to reach the desired position.

- Once this position is reached, in order to memorize it press the button ■ (for 5 sec) till the motor swivels 3 times.

WARNING: in case of error, repeat the procedure.

B- SETTING OF THE UPPER END STOP

WARNING: in case the installer needs to modify this end-stop, it is **ONLY** allowed to lower the upper end-stop position. **Do not try to raise the upper end-stop because this will cause severe damages to the product and this operation will invalidate the warranty.**

- Lower down the lift till half stroke, pressing the remote control button ▼ and stop it with button ■.

- Press the button ■ (for 5 secs) till the motor swivels 2 times.

- Press again the button ■ (for 5 sec) till the motor swivels 4 times.

- Press the button ▲ (for 5 sec) till the motor swivels 2 times.

- Press and hold the buttons ▼ or ▲ in order to reach the desired position of the lift. **Warning**: during this programming operation you have to keep the buttons ▼ or ▲ pressed in order to reach the desired position.

- Once this position is reached, in order to memorize it press the button ■ (for 5 sec) till the motor swivels 3 times.

WARNING: in case of error, repeat the procedure.

C- SETTING OF THE INTERMEDIATE STOP (PROJECTION MODE position)

- Lower down the lift till half stroke, pressing the remote control button ▼ and stop it with button ■.
- Press the button ■ (for 5 secs) till the motor swivels 2 times.
- Press again the button ■ (for 5 sec) till the motor swivels 4 times.
- Press simultaneously the buttons ▲+▼ (for 5 sec) till the motor swivels 2 times.
- Press and hold the buttons ▼ or ▲ in order to reach the desired position of the lift. Warning: during this programming operation you have to keep the buttons ▼ or ▲ pressed in order to reach the desired position.
- Once this position is reached, in order to memorize it press the button ■ (for 5 sec) till the motor swivels 3 times.

11.0 - USE OF THE REMOTE CONTROL AND CONNECTION OF LOW VOLTAGE CONTACTS

10.1 - USE OF THE REMOTE CONTROL

LOWER END STOP (service mode)

- Press the button ▼ in order to reach the lower-end stop (SERVICE mode).

UPPER END STOP

- Press the button ▲ in order to reach the upper-end stop.

INTERMEDIATE END STOP (projection mode)

- Press simultaneously the buttons ▲+▼ in order to reach the intermediate stop (PROJECTION mode).

10.2 - USE OF LOW VOLTAGE CONTACTS

How to connect the wired low voltage contacts:

LOWER END STOP (service mode)

- Close the connection, for at least 1 second, between the white-black and white-orange wires in order to reach the LOWER end stop (SERVICE mode).

UPPER END STOP

- Close the connection, for at least 1 second, between the white-black and white wires in order to reach the UPPER end stop.

INTERMEDIATE END STOP (projection mode)

- Close the connection, for at least 1 second, simultaneously between the white-black, white-orange and white wires in order to reach the INTERMEDIATE stop (PROJECTION mode).

